

Jerzy Smardzewski<sup>1</sup>, Silvana Prekrat<sup>2</sup>

# Nonlinear strength model of an eccentric joint mandrel

## Nelinearni model čvrstoće spoja svornjakom i zakretnim klinom

Izvorni znanstveni rad • Original scientific paper

Prispjelo - received: 08. 09. 2004. • Prihvaćeno - accepted: 24. 11. 2004.

UDK 630\*824;674.028

**ABSTRACT** • *The objective of this paper is to perform conduct experimental investigations of an eccentric joint of a metal mandrel and to develop a mathematical model of strength of a metal mandrel applied to assemble carcasses of cabinet furniture. On the basis of experiments, it is shown that the developed nonlinear models of eccentric joints describe correctly the phenomena occurring at the mandrel - chipboard contact.*

**Key words:** *digital image correlation, joint, numerical model, mathematical model.*

**SAŽETAK** • *Cilj je rada provesti eksperimentalna istraživanja i razviti matematički model za čvrstoću metalnog svornjaka sa zakretnim klinom za spajanje korpusa namještaja. Na temelju provedenih istraživanja pokazano je da razvijeni nelinearni model dobro opisuje pojave koje se događaju na mjestu dodira metalnoga svornjaka i iverice.*

**Ključne riječi:** *usporedba digitalnih slika, spoj, numerički model, matematički model*

### 1 INTRODUCTION

#### 1 UVOD

The strength of structural nodes of cabinet furniture is largely determined by the strength of mandrel-chipboard joints. It is evident from the distribution of internal forces generated during forced torsional deformations of a furniture carcass (Bachmann and Hassler 1975, 1976; Chia-Lin and Eckelman, 1994; Kuhne and Kropelin, 1978; Smardzewski and Prekrat, 2002) that the maximum loads occur in structural joints linking side walls with bottom rims and that these loads are located in wooden or metal joints of corner wall connections.

Due to the above described load distribution it is necessary to check the strength of the connection taking into con-

sideration the shear and compression strengths as well as the delamination resistance of the chipboard. Therefore, in the process of furniture design, strength calculations should be carried out on *in situ* models for which input data should come from elementary investigations on elastic properties of materials applied in manufacturing the joints.

It is clear from the research results published so far, that the calculation models of eccentric joints employed to assemble cabinet furniture are based primarily on far-reaching mathematical or numerical simplifications, which assume, as the basis of their considerations, the linear theory of elasticity of isotropic bodies (Chia-Lin and Eckelman, 1994; Ji-Lei-Zhang and Eckelman 1993; Smardzewski, 1998; Smardzewski and Prekrat 2002).

<sup>1</sup>Author is professor at Faculty of Wood Technology, Poznan University, Poland. <sup>2</sup>Author is assistant professor at Faculty of Forestry, Zagreb University, Croatia.

<sup>1</sup>Autor je redovni profesor na Fakultetu drvene tehnologije Sveučilišta u Poznau, Poljska. <sup>2</sup>Autor je docentica na Šumarskom fakultetu Sveučilišta u Zagrebu, Hrvatska.

Thus, in order to improve and rationalize the work of designers and make their calculations reliable, attempts are made to find models of mandrel strength of an eccentric joint, which are close to the real ones, and establish their corresponding numerical models.

Bearing in mind the above-presented arguments, the author decided to carry out experimental investigations and to develop a mathematical model of strength of a metal mandrel of an eccentric joint applied in the process of assembly of cabinet furniture carcasses. In addition, it was decided that the results of numerical calculations were to be verified employing the method of digital image correlation (DIC).

**2 MATERIAL AND METHODS**  
**2 MATERIJAL I METODE**

In most cases, screw fasteners in eccentric joints are mounted directly into the chipboard. References to their elastic properties can be found in appropriate literature on the subject and, in most cases, these results can be applied directly in practical engineering studies. Most frequently, in order to obtain the most reliable results of engineering calculations, in the case of chipboards, the orthotropic model of elastic properties is suggested, which takes into account different properties of near-surface layers and the central layer of chipboards.

For a three-layer chipboard of the thickness of  $h_{sub} = 18$  mm, the following values of elastic properties were assumed (Smardzewski and Prekrat, 2002):  $E_{x1} = 3850$  MPa;  $E_{x2} = 1030$  MPa;  $h_1 = 3$  mm;  $h_2 = 12$  mm and the Young's equivalent modulus of elasticity was calculated by use of the following correlations:

$$E_{sub} J_{sub} = \sum_{i=1}^n E_i J_i$$

$$E_{x-sub} h_{sub}^3 = 2E_{x1} (4h_1^3 + 3h_2 h_1 h_{sub}) + E_{x2} h_2^3$$

$$E_{x-sub} = 2523.2 \text{ MPa}$$

where:

$E_{x1}$  - Young's modulus of external layers in  $x$  - direction (*Youngov modul vanjskih slo-*

*jeva u smjeru osi x)*

$E_{x2}$  - Young's modulus of the central layer in  $x$  - direction (*Youngov modul središnjega sloja u smjeru osi x)*

$h_1, h_2$  - thicknesses of external and central layers of the chipboard (*debljine vanjskih slojeva i središnjega sloja iverice)*

$h_{sub}$  - thickness of three-layer chipboard (*debljina troslojne iverice)*

$E_{sub}$  - Young's equivalent modulus of three-layer chipboard in  $x$  - direction (*ekvivalentni Youngov modul troslojne iverice u smjeru osi x)*

$J_{sub}$  - moment of inertia of three-layer chipboard (*moment inercije troslojne iverice).*

For the majority of cases of the examined chipboards, the  $E_{x-sub}$  amounted to 2950 MPa, whereas the remaining moduli were  $E_{y-sub} = 2530$  MPa;  $E_{z-sub} = 95$  MPa, respectively. The respective Poisson's coefficients were:  $\nu_{xz-sub} = 0.282$ ;  $\nu_{xy-sub} = 0.207$ ;  $\nu_{zy-sub} = 0.045$ .

Bearing in mind the assumed proportions and the determined values of equivalent moduli of linear elasticity as well as Poisson's coefficients, the remaining elastic values for individual layers of the chipboard were determined (Table 1).

The load-carrying capacity of a threaded fastener of an eccentric joint was determined in a simple tensile test (Fig.1). When presenting values of forces in the displacement function for the examined fasteners of eccentric joints, the rigidity of the joint was also assessed and this was used as the basis for the determination of the type of numerical model in strength calculations. The performed investigations on the strength of metal mandrels of eccentric joints in the chipboard revealed their repetitive, non-linear transfer characteristics of operational loads. Therefore, in an attempt to represent real objects as closely as possible in the used numerical models, solid models were developed with metal contact elements-chipboard interface. In addition, attempts were also made to represent a three-layered system in the orthotropic model of the chipboard developed in the course of the technological cycle (Fig. 1). The loading of the mandrel was carried out assuming a 10

**Table 1**  
*Elastic properties of a three-layer chipboard*  
**Tablica 1.**  
*Elastična svojstva troslojne iverice*

Physical value <i>Fizikalna veličina</i>	Layer $h_1 = 3$ mm <i>Sloj <math>h_1 = 3</math> mm</i>	Layer $h_2 = 12$ mm <i>Sloj <math>h_2 = 12</math> mm</i>
$E_x$ , MPa	3850.0	1030.0
$E_y$ , MPa	3301.2	883.5
$E_z$ , MPa	123.9	33.2
$\nu_{xz}$	0.368	0.098
$\nu_{xy}$	0.270	0.072
$\nu_{zy}$	0.059	0.016

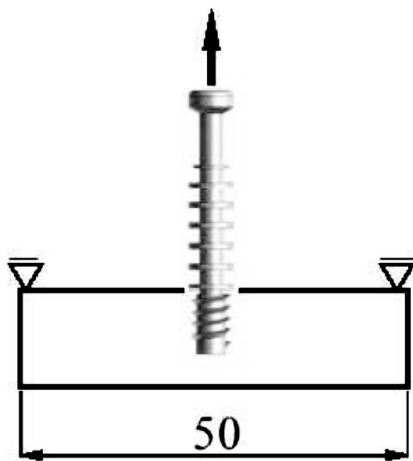

**Figure 1**  
Diagram of investigations on mandrel strength  
**Slika 1.**

Graf istraživanja čvrstoće svornjaka

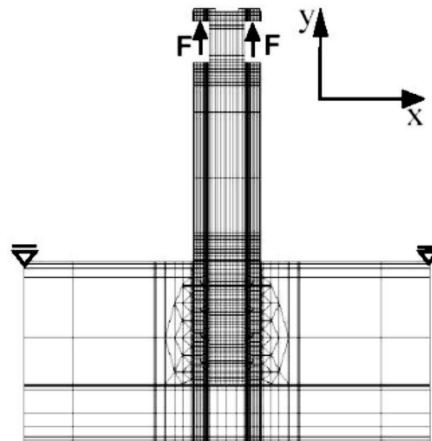
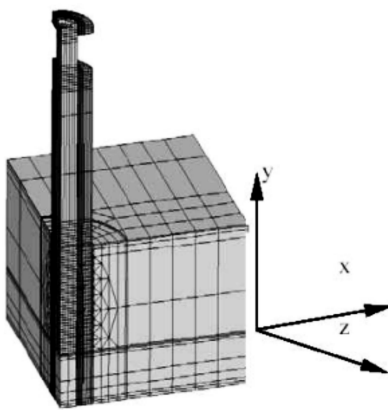

**Figure 2**  
FEM model of a sample with mandrel  
**Slika 2.**

FEM model uzorka sa svornjakom

second cycle of investigation and the value of maximum load of  $2F = 804$  N.

### 3 RESULTS AND DISCUSSION 3 REZULTATI I DISKUSIJA

#### 3.1 Analysis of numerical calculations

##### 3.1 Analiza numeričkih izračuna

In performing numerical calculations, the compatibility of the obtained results with those of experimental studies was assessed by comparing displacement values and deformation forms (Fig. 3). Maximum mandrel displacements determined in the results of numerical calculations corresponded to values recorded during laboratory experiments. A significant similarity was also found in the sample deformation formed following the effect of destructive force equaling 804 N.

Figure 4 shows the distribution of normal stresses  $S_{yy}$  determined at measuring points along axis y along the length of the nut body (i.e. in the chipboard) according to designations in Figure 5. It is evident from the data presented in this figure, that a relatively large displacement of 1.58 mm, following the application of force of 804 N,

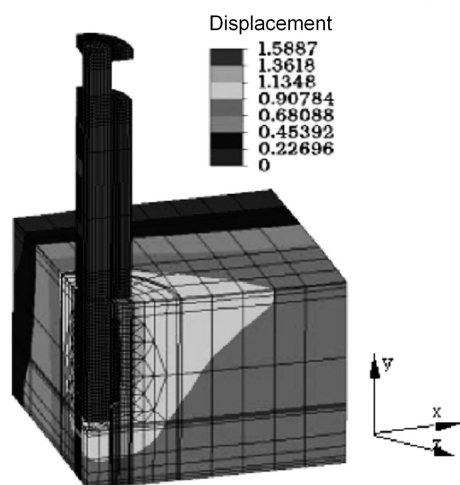
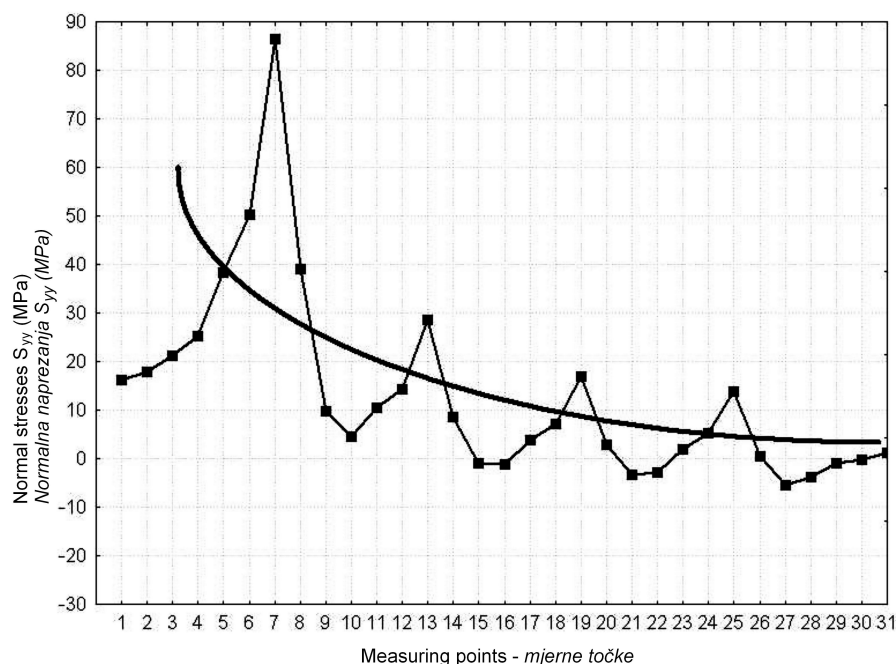

**Figure 3**  
Characteristics of mandrel strength  
**Slika 3.**

Svojstva čvrstoće svornjaka

was clearly caused by a large load of the first thread turn, in other words the first turn of the nut body formed by the mandrel thread contour. This is where normal stresses  $S_{yy}$  reached the maximum value of approximately 87 MPa and significantly exceeded the acceptable chipboard shear strength, which amounts to about 4 MPa. The fading amplitudes of maximum normal stresses  $S_{yy}$  in consecutive threads indicate a minimization of mandrel displacements and stopping of the last thread on the chipboard layer made of micro-chips. This

**Figure 4**  
Normal  $S_{yy}$  stresses in  
a chipboard  
**Slika 4.**  
Normalna  $S_{yy}$   
naprezanja u iverici



explains the regular occurrence of considerable material destructions of the central layer of chipboard and the elastic deformation of the layer containing micro-chips, which transfers acceptable stresses and prevents slipping of the mandrel from the sample opening.

On the other hand, Figure 6 shows tensile stresses generated in the core of the threaded part of the mandrel. As expected, these stresses increased with the distance from the bottom of the nut opening. Visible fading amplitudes of normal stresses were caused by bending of individual thread contours.

The above-presented results of numerical calculations allowed developing more general models of load carrying ability of the mandrel fastener of the eccentric joint.

### 3.2 Mathematical model of the joint

#### 3.2 Matematički model spoja

Practically speaking, the connection between the mandrel and chipboard should transfer only axial forces and turning moments resulting from assembly operations. In order to describe the distribution of stresses along the core of the thread or in the nut body of a furniture joint, it is necessary to describe the distribution of thread loads. A detailed model of a thread stress was described in an article by Dietrich et al. (1986), who explained causes and the character of variations in the load of individual threads. Let us now consider total relative displacements of selected threads  $i$  and  $j$  separated from each other by the distance

$\Delta_z$  along the axis (Fig. 7). We will then find an identification connection of elongations or shortening of the bolt and nut body together with deflections of observed threads:

$$\Delta u_s - \Delta u_n = (v_{is} + v_{in}) - (v_{js} + v_{jn})$$

where:

$\Delta u_s$  - expresses the change of distance of individual bolt threads following an elastic elongation or shortening of the bolt core (*označava promjenu dimenzije pojedinačnoga navoja svornjaka koja prati elastično produljenje ili skraćenje svornjaka*),

$\Delta u_n$  - expresses the change of distance of individual nut threads following an elastic shortening of the nut body (*označava promjenu dimenzije pojedinačnoga navoja uloška koja prati elastično skraćenje tijela navojnoga uloška*),

$v_{is}$ ,  $v_{js}$  - respectively, elastic deflection of the  $i$ -th or  $j$ -th thread of the bolt thread measured at the average thread cross-section (*elastična promjena  $i$ -tog ili  $j$ -tog navoja svornjaka mjerena na srednjem poprečnom presjeku navoja*),

$v_{in}$ ,  $v_{jn}$  - respectively, elastic deflection of the  $i$ -th or  $j$ -th thread of the nut cooperating with bolt threads (*elastična promjena  $i$ -tog ili  $j$ -tog navoja uloška u skladu s navojem na svornjaku*).

The degree of variations in the distribution of expenditures and stresses for the loaded parts of the thread can be expressed in the form of the following equations:

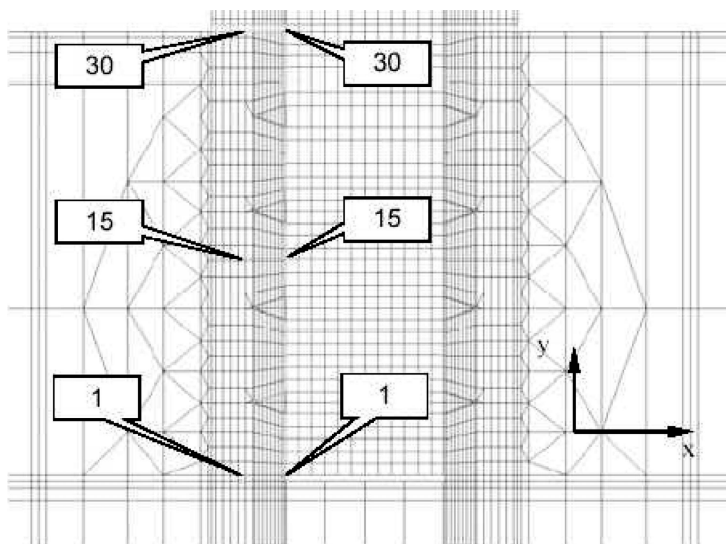

**Figure 5**  
Direction of the numeration of points at which stress values were determined  
**Slika 5.**  
Smjer obrojčavanja točaka u kojima je određena vrijednost naprezanja

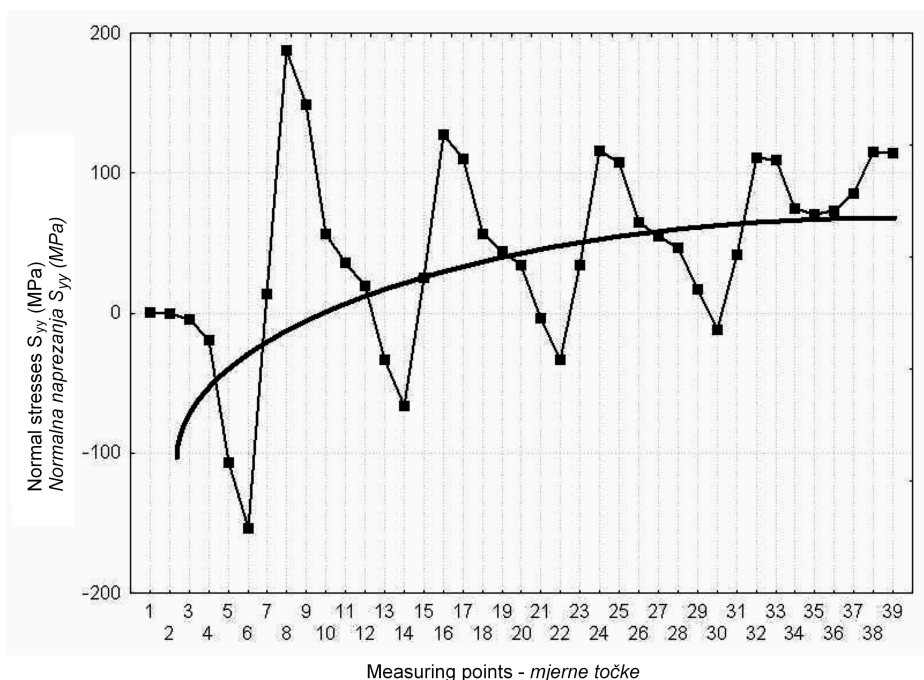

**Figure 6**  
Normal stresses  $S_{yy}$  in the core of mandrel thread  
**Slika 6.**  
Normalna naprezanja  $S_{yy}$  u središtu navoja svornjaka

$$q(z) = \frac{1}{k \sinh(km)} \left[ q'(m) \cosh(kz) - q'(0) \cosh(k(m-z)) \right]$$

where:

$$q'(0) = \frac{1}{C} \left( -\frac{F'_s}{E_s A_s} + \frac{F'_n}{E_n A_n} \right)$$

$$q'(m) = \frac{1}{C} \left( -\frac{F''_s}{E_s A_s} + \frac{F''_n}{E_n A_n} \right)$$

$$k^2 = \frac{e}{C}$$

$$e = \frac{1}{E_s A_s} + \frac{1}{E_n A_n}$$

$$C = \frac{P^2}{A_{0r}} \left( \frac{C_s}{E_s} + \frac{C_n}{E_n} \right)$$

$F'_s, F''_s, F'_n, F''_n$  - forces in the bolt (s) and nut (n) cross-sections before and after the thread (sila u poprečnom presjeku svornjaka (s) i navojnog uloška (n) prije i nakon navoja),

$E_s, E_n$  - Young's equivalent modulus of elasticity of the bolt (s) and nut (n) (Youngov ekvivalentni modul elastičnosti svornjaka (s) i navojnog uloška (n)),

$A_s, A_n$  - cross-sectional area of the bolt core (s) and the nut body (n) (površina poprečnog presjeka svornjaka (s) i tijela navojnog uloška (n)),

$A_{0r}$  - area of abut projection of a single thread on the plane perpendicular to the joint axis (površina projekcije jednoga navoja na ravninu okomitu na os spoja),

$C_s, C_n$  - non-dimensional coefficients for the bolt (s) and nut (n) dependent on dimensions of the thread model (bezdimenzional-

**Figure 7**  
Diagram of deformations of threads

**Slika 7.**  
Dijagram deformacija navoja

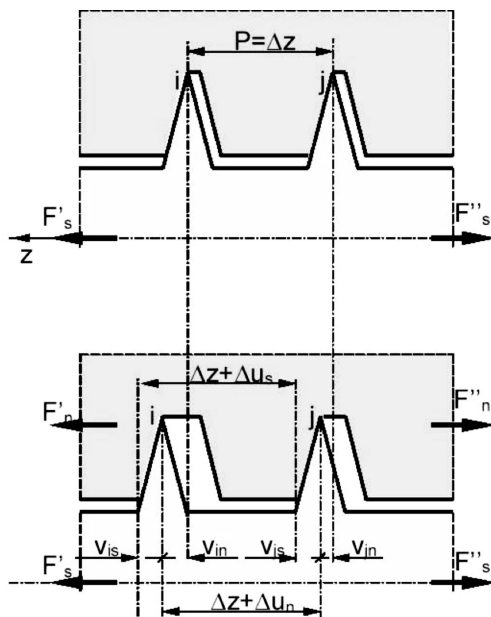

ni koeficijenti za svornjak i navojni uložak ovisno o dimenzijama modela navoja),  
*m* - length of thread (*duljina navoja*),  
*z* - coordinates on axis *z* (*koordinate na osi z*),  
*q* - distributing load (*kontinuirano opterećenje*),  
*P* - load of thread (*opterećenje navoja*).

Let us, now, consider cases of an operational load of mandrel with forces occurring either during assembly or use of the furniture carcass (Fig. 8). The initial stress caused by screwing in of the mandrel during the assembly of chipboard elements of furniture carcasses allows assuming the following work conditions of the joint: the screw core is stretched and the chipboard is compressed. The threshold conditions for the above assumptions can be expressed as follows:

for  $z = 0$

$$F_s'' = F$$

$$F_n'' = -F$$

for  $z = m$

$$F_s' = F_n' = 0$$

$$q'(0) = -k^2 F$$

$$q'(m) = 0$$

therefore

$$q(z) = \frac{kF}{\sinh(km)} \cosh(k(m-z))$$

The force necessary for the initial stress (before the piece of furniture is assembled) is determined by the condition of the chipboard compressive strength  $k_c^w = 4 \text{ MPa}$  and the value equal to the following is obtained:

$$F \leq n \frac{\pi(D^2 - D_2^2)}{4} k_c^w$$

therefore,  $F \leq 36.30 \text{ N}$ .

The moment *M* on the coupling screwing the mandrel into the chipboard should, therefore, amount to

$$M \leq \frac{FD_2 \left( \text{tg } \gamma + \frac{\mu}{\cos \alpha} \right)^2}{2 \left( 1 + \frac{\mu}{\cos \alpha} \text{tg } \gamma \right)}$$

hence,  $M = 88.42 \text{ Nmm}$ .

However, the joint work associated with forces caused by attaching fasteners and the assembly of furniture carcasses is much more disadvantageous. Nevertheless, the tension of the mandrel caused by the eccentric link should not exceed the value of the force possible to transfer because of the shear strength of the chipboard. Hence, under this condition, it is possible to determine the value of forces of work tension from the shear strength of the chipboard  $k_t^w = 3.5 \text{ MPa}$ :

$$F \leq \pi D m k_t^w$$

therefore,  $F \leq 560.5 \text{ N}$ , and moment *M* on the coupling

$$M \leq \frac{FD_2 \left( \text{tg } \gamma + \frac{\mu}{\cos \alpha} \right)^2}{2 \left( 1 + \frac{\mu}{\cos \alpha} \text{tg } \gamma \right)}$$

equals  $M = 1365.38 \text{ Nmm}$ .

For the above conditions of use of the analysed piece of furniture, both the mandrel core and the chipboard are subjected to stretching. We can, therefore, set the following work conditions of this connection: for  $z = 0$

$$F_s'' = F$$

$$F_n' = 0$$

for  $z = m$

$$F_s' = 0$$

$$F_n'' = F$$

$$q'(0) = -\frac{1}{C} \frac{F}{E_s A_s}$$

$$q'(m) = -\frac{1}{C} \frac{F}{E_n A_n}$$

$$q(z) = \frac{F}{Ck} \frac{1}{\sinh(km)} \left[ \frac{\cosh(kz)}{E_n A_n} + \frac{\cosh(k(m-z))}{E_s A_s} \right]$$

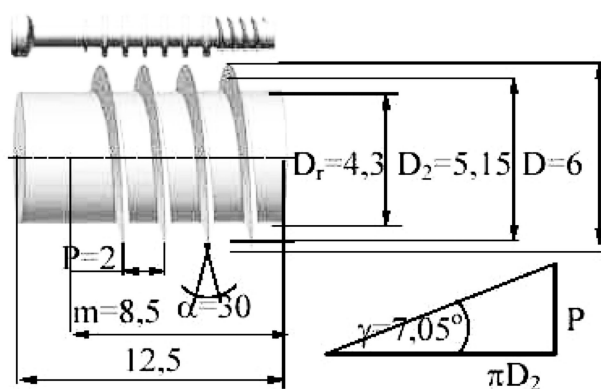

**Figure 8**  
Geometrical parameters of mandrel threads  
**Slika 8.**  
Geometrijski parametri navojnog uloška svornjaka

where

$$k^2 = \frac{e}{C}$$

$$e = \frac{1}{E_s A_s} + \frac{1}{E_n A_n}$$

$$C = \frac{P^2}{A_{0r}} \left( \frac{C_s}{E_s} + \frac{C_n}{E_n} \right)$$

$$C_s = 0.86 + 0.108 \frac{D_2}{P}$$

$$C_n = 1 + 0.234 \frac{D_2}{P}$$

Values of distributing load were determined assuming the following numerical data:  $m = 8.5$  mm;  $P = 2$  mm;  $A_{0r} = \pi(D_r)^2/4$ ;  $E_n = 1800$  MPa;  $E_s = 100\,000$  MPa;  $A_n = \pi(D_p)^2$ ;  $A_s = \pi(D_r)^2/4$ ;  $D_2 = 5.15$  mm;  $D_r = 4.3$  mm;  $D = 6$  mm.

On the basis of expenditure values, it can be noticed that the initial assembly stresses associated with setting the fastener in the chipboard do not contribute to a significant effort of the thread. It is only the operational stress, dependent on the character of work of the core and nut that increase considerably the level of expenditures to the value of 75 Nmm.

It is evident that the above-calculated, acceptable values of the axial load of the mandrel of the eccentric link (560 N) do not correspond to maximum axial load-carrying ability of this fastener obtained in experimental studies (804 N). This was the consequence of a strong concentration of stresses in the chipboard discussed earlier, which caused a permanent board deformation, considerable displacements and resting of mandrel threads on the stiff micro chips layer. On the other hand, in the analytical model, only the state of allowable compressive stresses were taken under considera-

tion in which case the thread contour in the nut body is not destroyed and its permanent deformations do not occur.

### 3.3 Registration of deformations using digital image correlation

#### 3.3 Snimanje deformacija usporedbom digitalnih slika

A comprehensive evaluation of the elaborated mathematical models of semi-rigid furniture joints required verification of the obtained research results. It was, therefore, decided to compare values of displacements determined numerically and experimentally with the results of investigations conducted with the assistance of the digital image correlation (DIC) method. Therefore, the same mandrel of the eccentric link positioned perpendicularly to the surface of the chipboard and loaded with a tensile force was subjected to a laboratory test (Fig. 9) during which the following parameters were to be determined:

- distance  $l_{12}$  between points 1 and 2,
- elongations  $\delta_{12}$  between points 1 and 2,
- distance  $l_{56}$  between points 5 and 6,
- elongation  $\delta_{56}$  between points 5 and 6,
- distance  $l_{26}$  between points 2 and 6,
- elongation  $\delta_{26}$  between points 2 and 6,
- change of angle  $\alpha_{31}$  of the line slope passing through points 31 as well as,
- change of angle  $\alpha_{12}$  of the line slope passing through points 12.

The experiment was carried out at a test station consisting of a numerically controlled testing machine, a computer, a monochromatic digital camera, a frame-grabber intended for image acquisition and IMAQ Vision Builder and LabView National Instruments® software. First, the image of an unloaded sample was taken (Fig. 9) and it was used to mark out points and directions of the measurement of displacements and deformations. Next, the sample was photographed in the course of a

**Figure 9**  
Designation positions and directions of displacements, unloaded sample  
**Slika 9.**  
Oznake pozicija i smjerova pomaka, neopterećeni uzorak

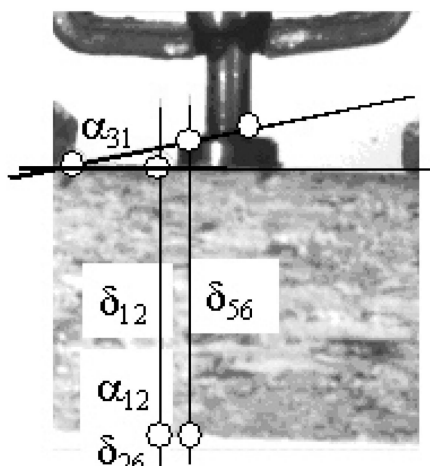

breaking stress (Fig. 10) and values of displacements of individual points as well as angles of rotation in directions controlled by these points were determined by applying the same measurement procedures. In order to reveal the type and form of defor-

**Figure 10**  
Designation positions and directions of displacements, loaded sample  
**Slika 10.**  
Oznake pozicija i smjerova pomaka, opterećeni uzorak

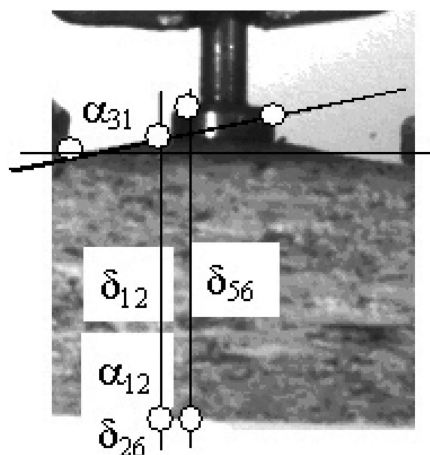

mations occurring on the surface of the chipboard element by use of the Pattern Matching method it was decided to assess global displacements of its characteristic points. The results of these investigations are presented in Table 2.

It is clear from the data presented in this Table that the mandrel displacement  $\delta_{56}$  caused by the breaking load of 804 N amounted to 1.63 mm. The value of this displacement determined in a mechanical sample on a testing machine reached 1.58 mm, whereas the one determined by use of numerical calcula-

tion - 1.59 mm. The difference between the obtained values amounted to 3.1% and indicated that the results of laboratory and analytical measurements were consistent. A considerable similarity of the  $\delta_{12}$  displacement value caused by chipboard de-lamination also deserves attention. The value of this displacement determined with the help of the DIC method was found to be at the level of 1.29 mm, while its value calculated numerically was 1.24 mm. This corresponded to 96.1% of the value determined optically. Another interesting result was a satisfactory consistency of the non-dilatational strain expressed in the change of the  $\alpha_{31}$  angle value measured between the horizontal line and the line connecting measurement points 3 and 1. This increase of 13.4° of the angle of rotation was also confirmed by the use of the numerical method and indicates both the correctness of the structural FEM models developed earlier and, at the same time, verifies positively the used method of digital image correlation as a tool suitable for the assessment of displacements and deformations of joints manufactured from porous materials. In addition, it is evident from the data shown in Table 1 that the sample did not undergo rotation in the direction 1.2 because  $\alpha_{31} = 0$ . Therefore, as assumed when numerical models were developed, this is the case of a pure axial stretching of the mandrel.

#### 4 CONCLUSIONS 4 ZAKLJUČCI

Further to the above-presented analysis of research results as well as their analysis the following conclusions can be drawn:

- the elaborated non-linear models of axially loaded eccentric joints describe phenomena occurring at the mandrel-chipboard contact correctly and quite accurately,
- numerical models of eccentric joints should be based on the use of contact elements and subjected to calculations in the area of non-linear mechanics,
- the digital image correlation method (DIC) verified the correctness of results of numerical calculations and measurement results

**Table 2.**  
Displacements and deformations of the joint loaded with the force of 804 N  
**Tablica 2**  
Pomaci i deformacije spoja opterećenog silom od 804 N

Measured value Mjerena vrijednost	Unit Jedinica	Values determined Snimljene vrijednosti		Values calculated – Izračunane vrijednosti (5) = (4) - (3)		
		before loading prije opterećenja	after loading nakon opterećenja	DIC*	experimentally ekperimentalno	numerically numerički
1	2	3	4	5	6	7
$\delta_{12}$	mm	18.00	19.29	1.29	-	1.24
$\delta_{56}$	mm	20.03	21.68	1.63	1.58	1.59
$\delta_{26}$	mm	1.81	1.82	0.01	-	0.00
$\alpha_{31}$	°	357.70	11.10	13.40	-	13.24
$\alpha_{12}$	°	0.40	0.40	0	-	0

DIC – digital image correlation (usporedba digitalnih slika)



carried out by the testing machine,

- the elaborated mathematical models can constitute components of expert systems used to assist furniture design.

## 5 LITERATURA

## 5 REFERENCES

1. Bachmann, G., Hassler, W. 1975: Die Festigkeit von verschiedenen Möbelkonstruktionen, ihren Elementen und Verbindungsmitteln. Teil 1. Holztechnologie 16, 210-221
2. Bachmann, G., Hassler, W. 1976. Die Festigkeit von verschiedenen Möbelkonstruktionen, deren und Verbindungsmitteln. Teil 2. Holztechnologie 17, 11-16
3. Chia-Lin Ho, Eckelman, C.A. 1994. The use of performance test in evaluating joint and fastener strength in case furniture. Forest Products Journal 44, 47-53
4. Dietrich M., et al. 1986. Podstawy konstrukcji maszyn. Państwowe Wydawnictwo Naukowe.
5. Kuhne, G., Kropelin, U. 1978. Untersuchungen zum Beanspruchungs-verhalten von Ecke-verbindingen durch Dubel. Holztechnologie 19, 95-99
6. Ji-Lei-Zhang, Eckelman C.A. 1993. The bending moment resistance of single-dowel corner joints in case construction. Forest Products Journal, 43, 19-24
7. Smardzewski, J. 1998. Numerical analysis of furniture constructions. Wood Science and Technology. 32, 273-286
8. Smardzewski, J., Prekrat S. 2002. Stress distribution in disconnected furniture joints. International conference, Furniture, Human, Design. Zagreb, 1-8.

Corresponding address:

prof. dr hab. ing., JERZY SMARDZEWSKI, PhD  
August Cieszkowski Agricultural University of Poznan, Faculty of Wood Technology  
Dept. of Furniture Design  
60-637 POZNAN, Wojska Polskiego 38/42  
POLAND  
e-mail: JSmardzewski@au.poznan.pl